

# GB HPT 25 1150x550



## EASY TO USE

Smooth lifting and lowering thanks to the proportional valve and the foot pedal.



## ROBUST

High-strength chassis with 100% automated robotics welding.



## EQUIPMENT

### STANDARD CONFIGURATION

- **Covered tiller:** Soft rubber covering grants operator comfort and helps to reduce vibration, enabling a more comfortable and secure grip.
- **Nylon steering wheels and rollers**



### WIDE SET OF OPTIONALS

It's possible to choose steering wheels and rollers among Polyurethane and Rubber to find the proper solution for each working conditions.

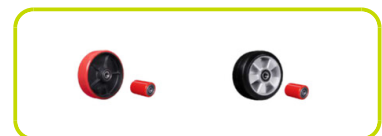

## Description

Manufacturer	LIFTER		
Drive	Manual		
Operator type	Pedestrian		
Load capacity	Q	kg	2500

## Weights

Service weight	kg	65
----------------	----	----

## Tyres/Chassis

Tyres: front wheels	NYLON		
Tyres: rear wheels	NYLON		
Tyre size: Steering wheels - Diameter	mm	180	
Tyre size: Steering wheels - Width	mm	50	
Tyre size: Load rollers - Diameter	mm	80	
Tyre size: Load rollers - Width	mm	70	
Tyre size: rear wheels - Q.ty (X=driven)	nr	4	

## Dimensions

Lift height	h3	mm	115
Height, lowered	h13	mm	85
Overall length	l1	mm	1530
Length to face of forks	l2	mm	380
Overall width (front/rear)	b1/ b2	mm	550
Fork dimensions - Width	e	mm	160
Fork dimensions - Length	l	mm	1150
Forks width	b5	mm	550

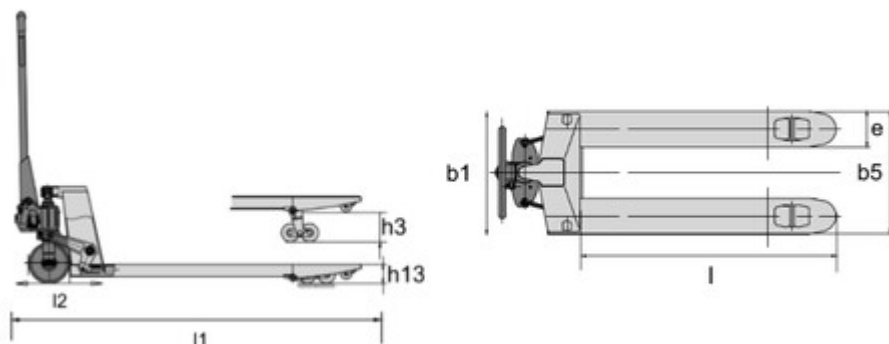

The information is aligned with the Data file at the time of download.  
Printed on 26/06/2024 (ID 187016)

©2024 | PR Industrial S.r.l unipersonale - Loc. Il Piano - 53031 Casole d'Elsa (SI) - ITALY.  
Company subject to the management and coordination of Generac Power Systems Inc. | All rights reserved | Image shown may not reflect actual package. Specifications subject to change without notice

